

# ENERGIZER LR820

**6V**



## Industry Standard Dimensions

mm (inches)

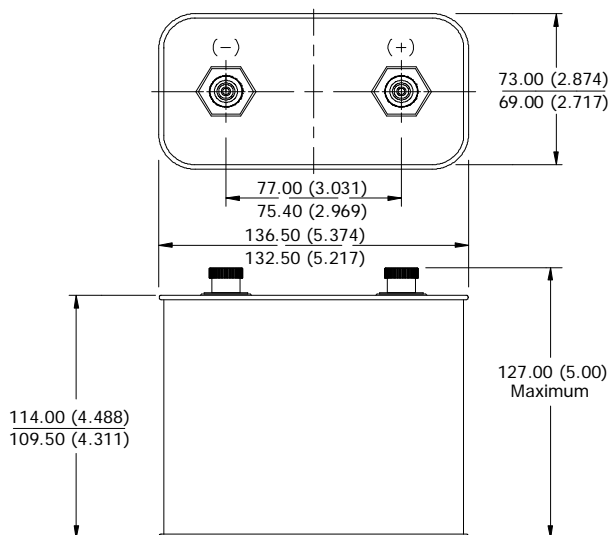

## Specifications

<b>Classification:</b>	Alkaline
<b>Chemical System:</b>	Zinc-Manganese Dioxide (Zn/MnO <sub>2</sub> ) No added mercury or cadmium
<b>Designation:</b>	IEC-4LR25-2
<b>Nominal Voltage:</b>	6.0 volts
<b>Operating Temp:</b>	-18°C to 55°C
<b>Typical Weight:</b>	1340 grams
<b>Typical Volume:</b>	1125 cubic centimeters
<b>Jacket:</b>	Metal
<b>Cells:</b>	Eight 3-350 (2 strings of 4 in series) Four in series
<b>Terminal:</b>	Screw Post

## IEC Industry Standard Road Warning Test (21°C)

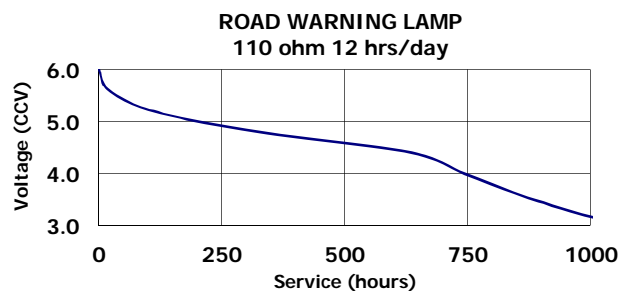

## IEC Industry Standard Portable Lighting Tests (21°C)

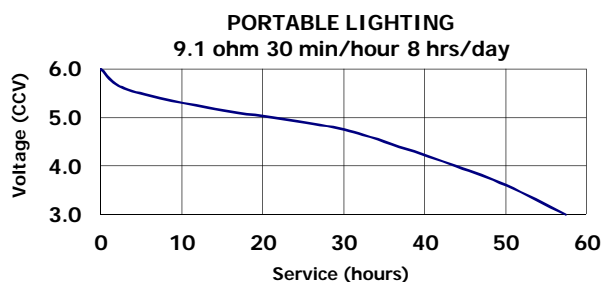
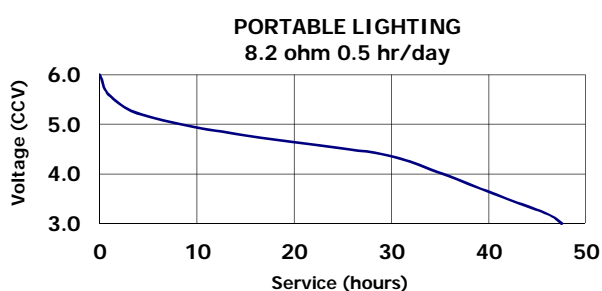

### Important Notice

This datasheet contains typical information specific to products manufactured at the time of its publication.

©Energizer Holdings, Inc. - Contents herein do not constitute a warranty.